

# Eclipse Linnox Burners

Model CCS-LS-HC (High Capacity)  
Version 1

Parameter		Specifications
Heat Input at Neutral Conditions (based on gross calorific values) Natural Gas SP GR 0.64 Propane SP GR 1.5	Basic Element Modules	Input per lineal foot of burner (300mm)
	240 CCS-LS	910,000 BTU/hr/LF (266 kW)
	360 CCS-LS	1,365,000 BTU/hr/LF (400 kW)
	480 CCS-LS	1,820,000 BTU/hr/LF (532 kW)
	720 CCS-LS	2,725,000 BTU/hr/LF (789 kW)
Turndown		10:1
Fuels		Natural Gas, Propane
Inlet Pressure at Ratio Regulator		Minimum 40" w.c. (100 mbar)
Pilot Requirements		1 m <sup>3</sup> /hr gas at 20 mbar (approximate) 1 m <sup>3</sup> /hr air at 20 mbar (approximate)
Combustion Air Pressure		19.5" w.c. at mixer inlet (50 mbar) (Neutral chamber pressure)
Excess Air		40 - 60% approximate
Flame Length		15" (380mm) with module 120 (measured from end of burner shields)
Flame Monitoring		Flame Rod UV Scanner Self Check UV Scanner
Ignition		Direct with gas support, at 30% input Pilot at 30% of input
Emissions (estimated)		< 15 ppm NO <sub>x</sub> at 3% O <sub>2</sub> (< 3 ppm NO <sub>x</sub> at 17% O <sub>2</sub> ) (Nat. Gas) <100 ppm CO at 3% O <sub>2</sub> (< 22 ppm CO at 17% O <sub>2</sub> )
Process Conditions	Recirculation Temp	840°F Maximum (450°C)
	Outlet Temp	1470°F Maximum (800°C)
Combustion Air Preheat		Contact Factory
Process Air Velocity Past Burner		390 fpm (2 m/s) minimum 4900 fpm (25 m/s) maximum Recommended velocity < 2000 fpm (<10 m/s) <b>WARNING:</b> Velocity perpendicular to the flame not allowed <b>WARNING:</b> High air flow past burner will affect emissions

- All inputs based upon gross caloric values.
- The estimated emissions are not to be used as guaranteed values. These values can be influenced by process conditions.
- Eclipse reserves the right to change the construction and/or configuration of our products at any time without being obliged to adjust earlier supplies accordingly.

## Performance Graphs

### $\Delta P$ vs. Input (Approximate Adjustment Pressures)

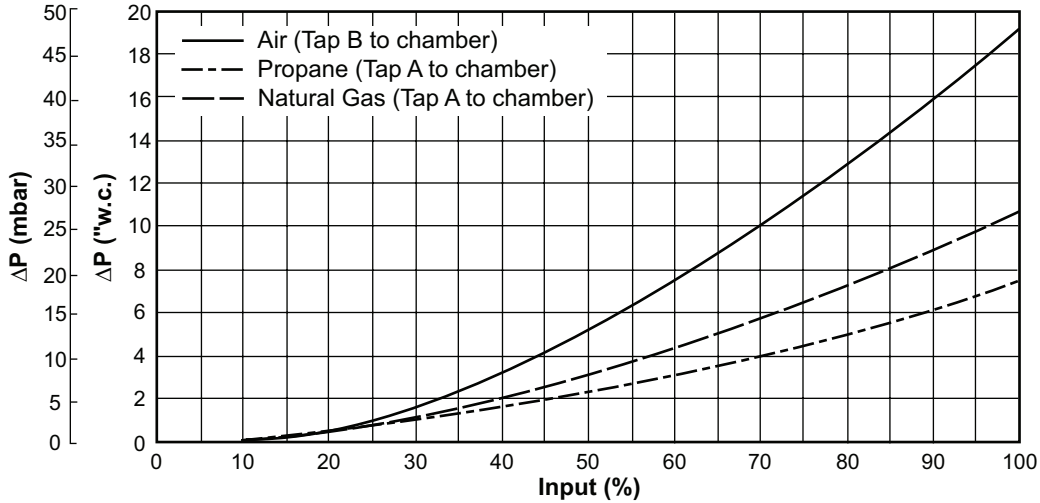

Air and gas differential pressures are based on 60% excess air. At lower excess air levels the air and gas differential pressures will be lower for a given input.

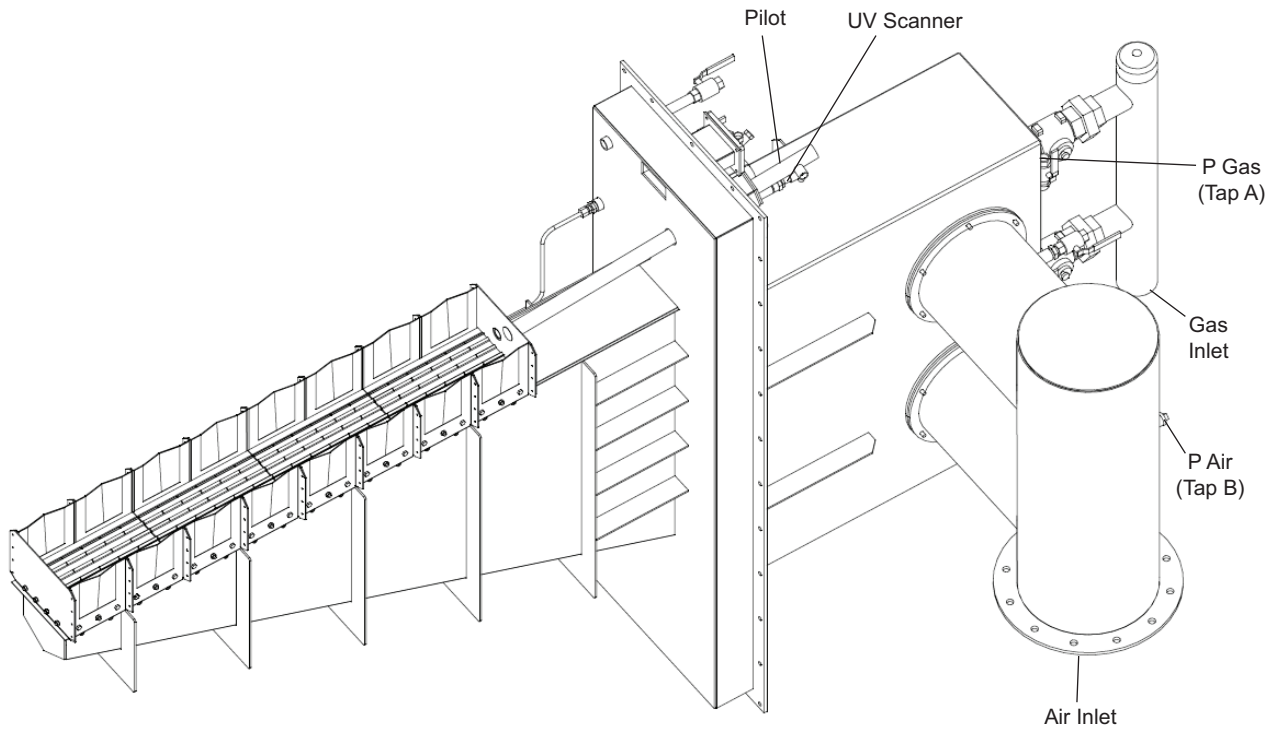

### Ordering Information Required

1. Basic element modules required (based on BTU/hr/lineal ft.)
2. Total length of burner needed.
3. Size of duct.
4. Dimension required from sideplate to first burner element.

### Sideplate Burner Dimensions

Sideplates are arranged for mounting to a side opening in the process air ducting. The sideplate is manufactured from sheet and is painted with a heat resisting gray coating. Sideplate dimensions vary due to mixer chamber sizing (dependent on chosen element module and total input). Drawings may be requested to obtain actual dimensions per burner application.

## Firing Arrangements

Burners can be configured to fire vertically (up or down) or horizontally (left or right). Systems include complete duct mounted burner sections, side-plate assemblies for insertion into an existing duct.

**Horizontal Mounting & Firing  
(Top View)**

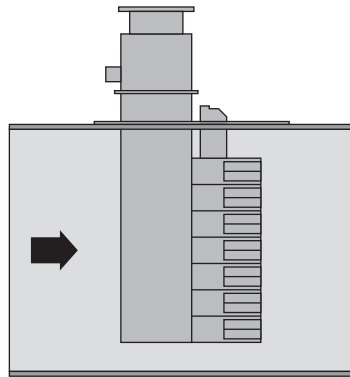

**Slot Firing  
(Top View)**

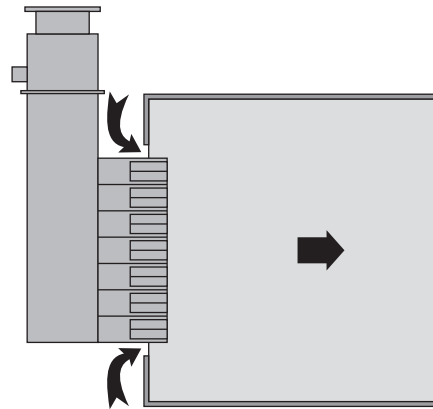

## Good Duct Design

The Linnox duct / side-plate unit must be properly installed in the process air duct system so that the process air velocity past the burner remains uniform. The illustrations below represent good duct designs which will best maintain the process air velocity. The shaded area represents the Linnox burner.

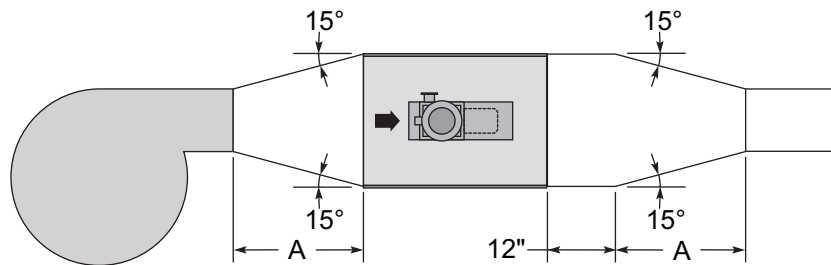

*Provide length A sufficient for maximum 15° taper*

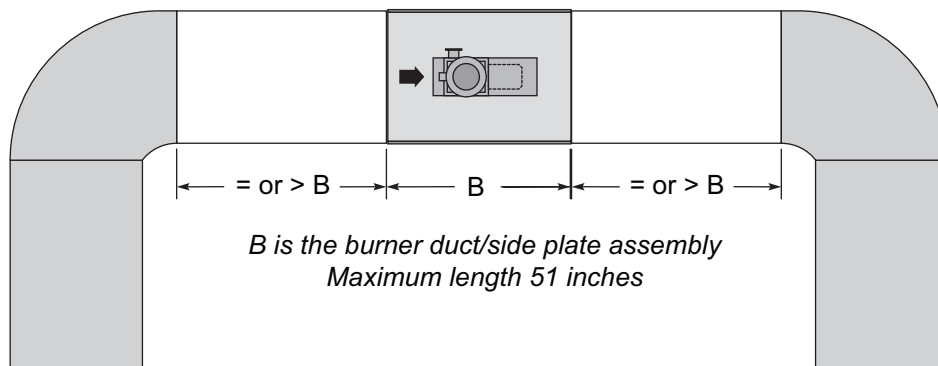

*B is the burner duct/side plate assembly  
Maximum length 51 inches*

For a detailed, (application specific) system design, contact Eclipse or your local Eclipse representative.



**Offered By:**

Power Equipment Company  
2011 Williamsburg Road  
Richmond, Virginia 23231  
Phone (804) 236-3800  
Fax (804) 236-3882

---

[www.peconet.com](http://www.peconet.com)